

VQ400M SERIES

CLASS "A" COMBINATION VALVES

PRODUCT HANDBOOK

APPLICATION



Figure 1 VQ420M & VQ425M

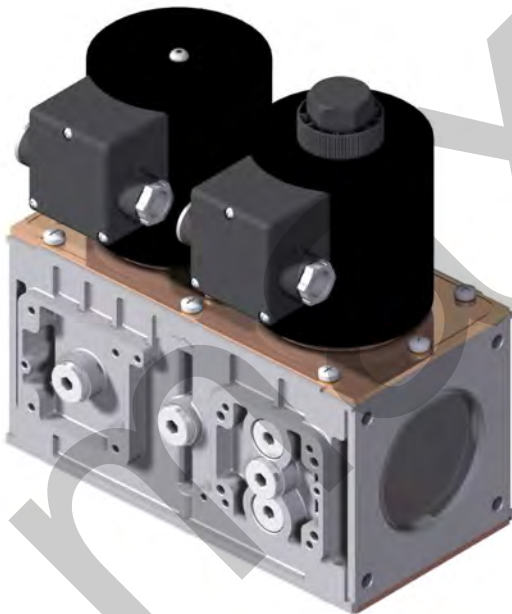

Figure 2 VQ440M & VQ450M

The VQ400M Series class "A" safety combination valves are used for control and regulation of gaseous fluids in gas power burners, atmospheric gas boilers, melting furnaces, incinerators and other gas consuming appliances.

The VQ400M offers flexibility to mount accessories like valve-position indicator, pressure indication switches, vent-valves or by-pass valves at several positions at the gas valve, whenever, wherever.

These combination valves are available in two body sizes:

- Small model
 - VQ420
 - VQ425
- Large model
 - VQ440
 - VQ450

All models are connected at suitable sized gas pipes by flange kits which can be ordered separately in several sizes.

CONTENTS

VQ400M SERIES	1
CLASS "A" COMBINATION VALVES	1
APPLICATION	1
Contents	2
FEATURES	2
DESCRIPTION	3
SPECIFICATION	3
Models	3
Dimensions	3
Pipe sizes	4
Capacity	4
Connections	4
Torsion and bending stress	4
Supply voltages	4
Electrical equipment	4
Electrical connections	5
Ambient temperature range	5
Coil insulation solenoid valves	5
Enclosure	5
Body material	5
Closing spring	5
Valve plunger	5
Seals and gaskets	5
Power consumption	5
PERFORMANCE CHARACTERISTICS	6
Opening time	6
Closing time	6
Maximum working frequency	6
Duty cycle	6
Operational voltage range	6
Designed life time	6
CAPACITY CURVES	7
INSTALLATION	8
IMPORTANT	8
WARNING	8
Maintenance and service	8
Mounting position	8
Mounting location	8
Main gas connection flanged valves	9
WARNING!	9
Electrical connection	9
WARNING	9
Wiring	9
ADJUSTMENTS AND FINAL CHECKOUT	11
CAUTION	11
2 nd main valve fast opening	11
2 nd main valve slow opening	11
IMPORTANT	11
Final checkout of the installation	12
OPTION INSTALLATION	13
WARNING	13
CONSTRUCTION AND WORKING PRINCIPLES	13
ORDERING INFORMATION	14
NOTE	14
Replacement of parts	15
Warning	15
Recommended accessories	15
APPROVALS	17
Declaration of Conformity	17

FEATURES

- Class "A" safety combination valve for control of gaseous fluids in gas consuming appliances in accordance with international standards.
- Main body with two gas valves with single seat.
- Possibility of installing internal by-pass valve to achieve high-low flame control.
- Possibility of installing internal or external pilot valve.
- Possibility of installing vent valve.
- Possibility of installing flanged minimum and maximum pressure switches.
- Possibility of installing valve Proving System (VPS).
- Possibility of mounting Closed Position Indication switch (CPI) at bottom of safety valve V1 and / or valve V2.
- Closing time: < 1 second.
- Coils field replaceable.
- Coils suitable for permanent energizing.
- Fine mesh screen between inlet flange and main body (optional).
- Various pressure tap points at main body available
- Second main valve, either with adjustable flow regulator (fast), or characterized opening mechanism (slow) with adjustable maximum flow rate and step pressure.
- Rectifier boards field replaceable.
- PG11 cable strain relief standard at VQ400M.
- Plug connector according to ISO 4400 / DIN EN 175301-803 optional for VQ400M.

DESCRIPTION

The VQ400M Series combination valves are suitable for the control of gaseous fluids in gas consuming appliances according to international standards.

The VQ400M Series combination valves meet the class "A" specification according EN161. The VQ400M Series combination valves can be ordered with straight flanged pipe connection from 1/2 " up to 2". The VQ400M Series combination valves are standard equipped with two safety valves V1 and V2. The first valve (V1) is always fast opening. The second valve (V2) can be either fast or slow opening.

- Standard the second valve (V2) is supplied with throttle screw (fast opening with flow regulation).
- Optionally the second valve (V2) can be ordered with slow opening device (with flow regulation and adjustable opening).
- Optionally the second valve (V2) can be ordered fast open, without any regulation device.

SPECIFICATION

The specifications described in this chapter are related to the main gas valves.

Models

Models can be ordered according order specification numbering which is shown in Figure .15

For an overview of all known combinations see surveys:

- 50040300
- 50040301 (Accessories)

The VQ400M series combination valves are available in two body sizes:

- Small model
 - VQ420M
 - VQ425M
- Large model
 - VQ440M
 - VQ450M

All models are connected at suitable sized gas pipes by flange kits which have to be ordered separately.

Dimensions

Main dimensions of the models are given at installation drawings:

Table 1 Overview of installation drawings.

Model	Installation drawing
VQ420M	INST0171
VQ425M	INST0172
VQ440M	INST0169
VQ450M	INST0170

Installation drawings are available in Honeywell documentation centre "HotDocs" and can be supplied digitally on request through Honeywell sales representative.

Pipe sizes

For connecting with several pipe sizes it is recommended to mount Honeywell flange kits which can be ordered separately as indicated below.

Table 2 Overview of recommended pipe sizes.

Gas valve	Recommended pipe size	Option
VQ420M	½"	1
VQ420M	¾"	2
VQ425M	1"	
VQ440M	1 ¼"	1
VQ440M	1 ½"	2
VQ450M	2"	

Recommended flanges for each model to be mounted are given in table 3 and table 4.

Capacity

Main body: see capacity curves at Figure .

Maximum operating pressure is 360 mbar for all models

- 360 mbar
 - VQ420M
 - VQ425M
 - VQ440M
 - VQ450M

Connections

As shown in the figure below, VQ400M is provided with plugs and flanges giving flexibility to customize this combination valve with Honeywell accessories.

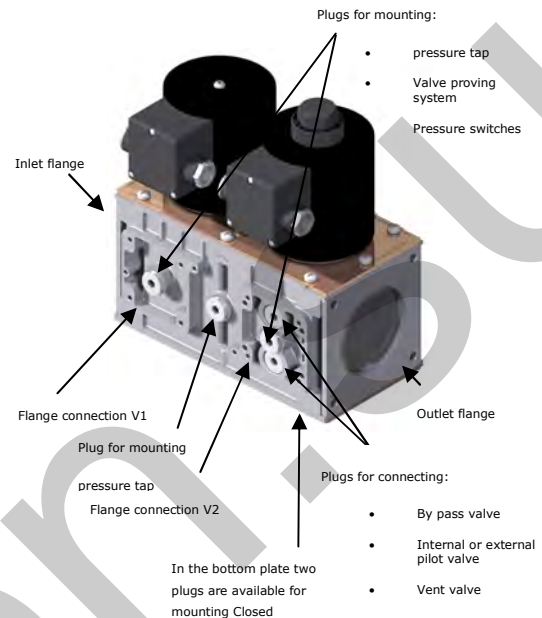

Figure 3 Interfaces for possible accessories

Torsion and bending stress

Pipe connections meet group 2 according to EN161 requirements.

Supply voltages

VQ400 M series can be ordered for line voltage:

- 230 Vac, 50/60 Hz
- 115 Vac, 50/60 Hz
- 120 Vac, 50/60 Hz

Electrical equipment

AC rectified coils with separated rectifier inside the cover.

Electrical connections

VQ400M: standard plug connection according PG11 on main gas valves and additional valves.

Optional: three pin plug connector („DIN plug“) on main gas valves and additional valves.

Ambient temperature range

VQ400M is designed to operate in ambient temperature levels between: -15 ... 60 °C

Coil insulation solenoid valves

Insulation material is specified according class F.

Enclosure

IP54 in combination with PG11 connection.

IP65 in combination with DIN-plug connection.

Body material

Aluminum alloy die cast body.

Closing spring

AISI 302 steel

Valve plunger

Chrome plated Fe 360B steel sliding on anti-friction bearing.

Seals and gaskets

Hydrocarbon resistant NBR rubber type

Power consumption

Honeywell provides VQ400M with coils that suit demands of specified inlet pressure levels. An overview of power consumption for different applications is given in the table below.

Table 3 Power consumption of each VQ400M main valve for 360 mbar applications.

	115V	120V	230V
VQ420M	16,5	18	15
VQ425M	23,9	26,1	21,1
VQ440M	52	56,7	46,5
VQ450M	-	-	61

PERFORMANCE CHARACTERISTICS

Opening time

The first valve (V1) opens in less than 1 second.

The second valve (V2) can be either a fast opening valve which opens in less than 1 second or a characterized opening valve which is adjustable from 1 up to 30 seconds, at rated capacity.

The opening characteristic is factory set at approximately 6 seconds at the following conditions:

- measured at 80 % of rated capacity
- 30 mbar supply pressure
- nominal voltage
- 20 °C
- 2,5 mbar pressure drop
- no step pressure

Due to the influence of ambient temperature (-15 ... 60 °C) the adjusted opening time of 6 seconds measured at 80% of adjusted flow rate can vary +/- 4 seconds.

Closing time

Less than 1 second for both valves.

Maximum working frequency

VQ400M is equipped for maximal working frequency of one cycle per minute.

Duty cycle

Coils are suitable for permanent energizing.

Operational voltage range

The combination gas valve will function satisfactory between 85% and 110% of the rated voltage.

Designed life time

Overview of designed life time is given in the table below.

Table 4 Number of cycles per model.

Model	Number of cycles
VQ420MA	500.000
VQ425MA	500.000
VQ440MA	300.000
VQ450MA	300.000

CAPACITY CURVES

For comparison an overview of specified capacity of VQ400M is shown in table 5.

Table 5 Overview of reference capacity in m³/h air at $\Delta p = 2.5$ mbar.

Gas valve	Flange size	Pipe size	Flow capacity
VQ420MA	DN15	½"	-
VQ420MA	DN20	¾"	8
VQ425MA	DN25	1"	11
VQ440MA	DN32	1 ¼"	25
VQ440MA	DN40	1 ½"	31
VQ450MA	DN50	2"	40

In figure 4 a broader range of specified capacity for VQ400M is shown in curves.

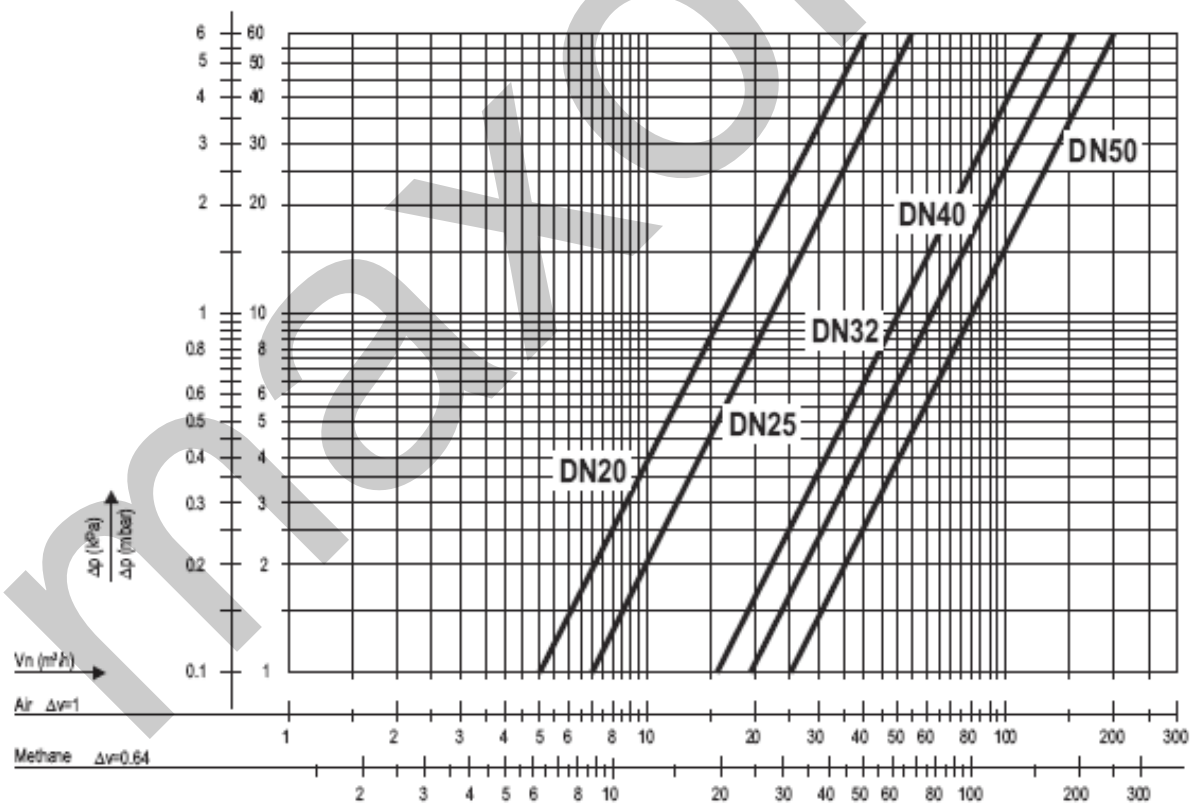

Figure 4 Capacity curve for VQ400M Series class „A” combination valves.

INSTALLATION

IMPORTANT

1. Read these instructions carefully. Failure to follow the instructions could damage the product or cause a hazardous condition.
2. Check the ratings given in the instructions and on the product to make sure the product is suitable for your application.
3. The installation has to be carried out by qualified personnel only.
4. Carry out a thorough checkout when installation is completed.

WARNING

- Turn off gas supply before installation.
- Disconnect power supply to the valve actuator before beginning the installation to prevent electrical shock and damage to the equipment.
- Do not remove the seal over valve inlet and outlet until ready to connect piping.
- The valve must be installed so that the arrow on the valve points in the direction of the gas flow (gas pressure helps to close the valve).

Maintenance and service

The designed lifetime* of this product is 10 years, based on date code, according to:

- a) the standard EN 126
- b) the table on designed lifetime as stated on the Afecor website <http://www.afecor.org/>

We cannot assume that the product can be safely used beyond the mentioned designed lifetime. This lifetime is based on use of the control according manufacturer's instructions.

Regular inspection of the control by authorized personnel in accordance with guidelines of the appliance manufacturer is required.

After reaching the designed lifetime the product has to be replaced by authorized personnel.

Note: * Warranty as opposed to designed lifetime is described in the delivery terms.

Mounting position

The gas valve can be mounted in vertical position with the coils at top side. The gas valve can be mounted plus or minus 90 degrees from the vertical.

Mounting location

The distance between the gas valve and the wall/ground must be at least 30 mm.

Main gas connection flanged valves

1. Take care that dirt does not enter the gas valve during handling.
2. Remove the flanges from the valve.
3. Use a sound taper fitting with thread according to ISO 7-1 or new, properly reamed pipe, free from swarf.
4. Apply a moderate amount of good quality thread compound to the pipe for fitting only; leaving the two end threads bare, PTFE tape may be used as an alternative.
5. Screw the flanges onto the pipes.
6. Ensure that inlet and outlet flanges are in line and separated from each other enough to allow the valve to be mounted between them without damaging the gasket.
7. Place gasket. If necessary grease it slightly to keep it in place.
8. Mount gas valve between flanges using the bolts for each flange.
9. Complete the electrical connections as instructed in the electrical connection section.

WARNING!

Tightness test after installation

- Spray all pipe connections and gaskets with a good quality gas leak detection spray.
- Start the appliance and check for bubbles. If a leak is found in a pipe connection, remake the joint. A gasket leak can usually be stopped by tightening the mounting screws, otherwise, replace the gas valve.

Electrical connection

WARNING

- Switch off power supply before making electrical connections.
- All wiring must comply with local codes, ordinances and regulations.

Use lead wire which can withstand 105 °C ambient.

The electric ON/OFF operator is provided with a terminal block for electrical connections.

Wiring PG11

Small models VQ420M-VQ425M

Remove screws (A).

Take off protective cover lids and gaskets (B).

Take off plugs Pg11 from holes (Figure 5):

(K) and (N) – for connecting separately.

(K), (L) and (M) – for connecting by common supply from inlet side.

(N), (L) and (M) – for connecting by common supply from outlet side.

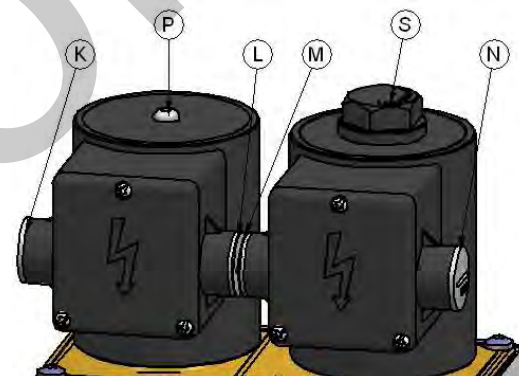

Figure 5 IP54 version closed by plugs

Prepare cables

- Remove plastic outside insulation for about 50-75 mm.
- Strip wires from plastic insulation for about 5-7mm.

Place cable support screw (C), steel ring (D), rubber ring (E) and guide wires through the hole in the cover to the connection block (F).

Connect wires between plates by tightening the particular screws (F1, F2, F3)

- Left: Phase
- Middle: Earth connection
- Right: Neutral

If common supply:

Loose screw (P) and cap (S). Turn coils and insert adaptor (G).

Turn back coils and tight screw (P) and cap (S) by tightening torque 2,5 Nm.

Connect corresponding contact by wires through adaptor.

Tight cable support screws (C)

Place gaskets and cover lids in position (B)

Place screws (A) and tight.

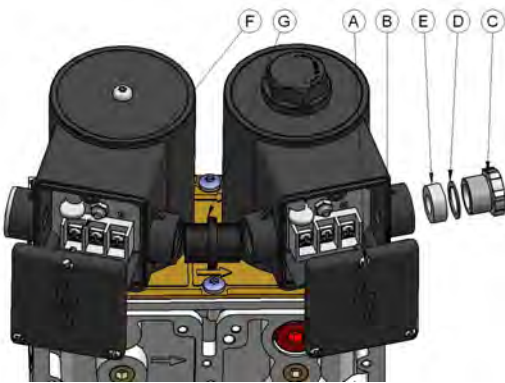

Figure 6 Small model connected by common supply from outlet side

Large models VQ440M-VQ450M

Each coil have to be supply separately.

Remove screws (A)

Take off protective cover lids and gasket (B)

Take off one from two plugs Pg11.

Prepare cables

- Remove plastic outside insulation for about 50-75 mm.
- Strip wires from plastic insulation for about 5-7mm.

Place cable support screw (C), steel ring(D), rubber ring (E) and guide wires through the hole in the cover to the connection block (F).

Connect wires between plates by tightening the particular screws (F1, F2, F3)

- Left: Phase
- Middle: Earth connection
- Right: Neutral

Tight cable support screws (C)

Place gaskets and cover lids in position (B)

Place screws (A) and tight.

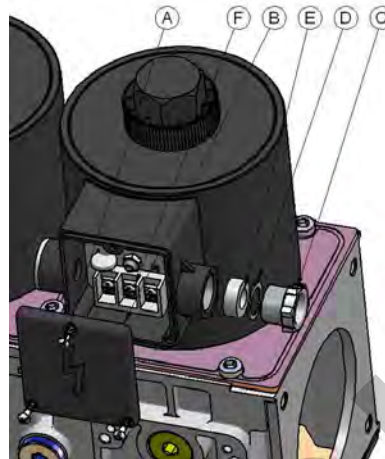

Figure 7 Large model – V2 coil connected from outlet side

Wiring DIN plug

Follow the instructions supplied by the appliance manufacturer as shown in the figures below. Coils supply separate

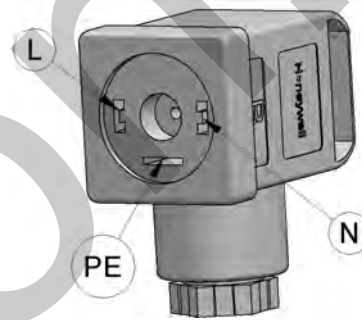

Figure 8 Three pin electrical plug connector (according to ISO 4400 / DIN EN 175301-803).

ADJUSTMENTS AND FINAL CHECKOUT

The procedures described in this chapter are related to the adjustments on the main gas valve, pilot valve and by-pass valve. For adjustments on the other additional functionalities (e.g. pressure switch), refer to the included instruction sheet of the product in question in the package.

CAUTION

- Adjustments must be made by qualified personnel only.
- To ensure a safe closing of the valves, it is essential that voltage over the terminals of operators is reduced to 0 Volts.

2nd main valve fast opening



Figure 9 Adjusting flow rate.

Flow rate adjustment (see Fig. 9.)

1. Remove the cap screw from top of the coil.
2. Place a socket head wrench into the adjustment nut.
3. Turn wrench counter-clockwise to increase or clockwise to decrease flow rate.
4. Replace cap screw.

2nd main valve slow opening

The following characteristics can be adjusted:

- flow rate
- step pressure
- opening speed

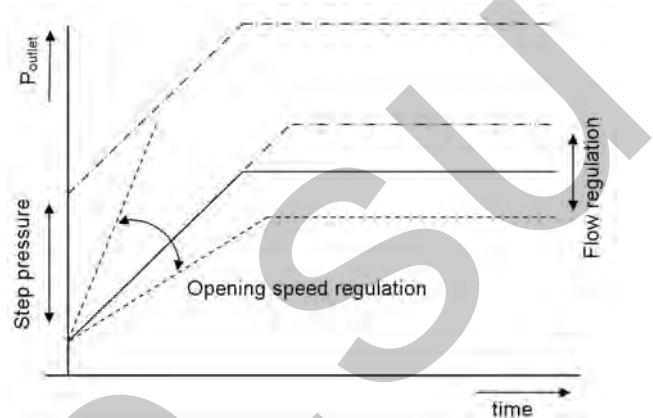

Figure 10 Characterized opening.

IMPORTANT

To ensure a satisfactory setting of the valve the pressure drop over the valve should be at least 10% of the supply pressure or 2.5 mbar whichever is the greatest.

Flow rate adjustment

1. Remove the cap from top of the coil by loosening both screws.
2. Place a wrench on the adjustment hexagon nut.
3. Turn wrench counter-clockwise to increase or clockwise to decrease the flow rate.
4. Replace cap on top of the coil.



Figure 11 Adjusting flow rate.

Step pressure adjustment (see fig. 12.)

1. Remove the cap from top of the coil by loosening both screws.
2. Place a screw driver in the slot of adjustment screw which is situated in center of the valve.
3. Turn screw driver counter-clockwise to increase or clockwise to decrease step pressure.
4. Replace cap on top of the coil.



Figure 12 Adjusting step pressure.

Opening speed adjustment

1. Remove the cap from top of the coil by loosening both screws.
2. Place screw driver in the slot of adjustment screw which is of center line.
3. Turn screw driver counter-clockwise to increase the opening speed and therefore the time till full opening will decrease.
4. Turn screw driver clockwise to decrease the opening speed and therefore the time till full opening will increase.
5. Replace cap on top of the coil.

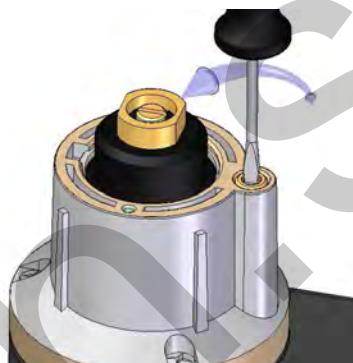

Figure 13 Adjusting opening speed.

Final checkout of the installation

Set the appliance in operation after any adjustment and observe several complete cycles to ensure that all burner components function correctly.

OPTION INSTALLATION

Installation can be done by the OEM or by qualified personnel in field.

WARNING

If additional hardware needs to be installed on field, then installation personnel should take care, that the main gas flow to the appliance has been completely stopped by an upstream manual shut-off valve prior to the installation.

Installation

1. Open the required gas flow channels by removing the suitable plugs from the valve body.
2. Take care that dirt can not enter the gas valve during handling
3. Install the screw-in additional hardware as required (vent, by-pass, external pilot valve)
4. Please refer to the relevant instruction sheet

CONSTRUCTION AND WORKING PRINCIPLES

The VQ400M combination gas valves are 2 x class "A" fail safe shut-off valves. The valve is opened by energizing the direct ON / OFF operator. The direct ON / OFF operator consists of a coil and stop sleeve assembly. Inside the top sleeve assembly a plunger is placed which is able to move up and down and thus opening or closing the valve. The plunger is gliding on two anti-friction bearings. Flow regulation is done by adjustable plunger stroke. A strainer made out of steel AISI 303 is incorporated between inlet flange and main body. Valve closing springs are made out of steel AISI 302. Seals and gaskets are manufactured out of hydrocarbon resistant NBR according to DIN 3535 and EN291.

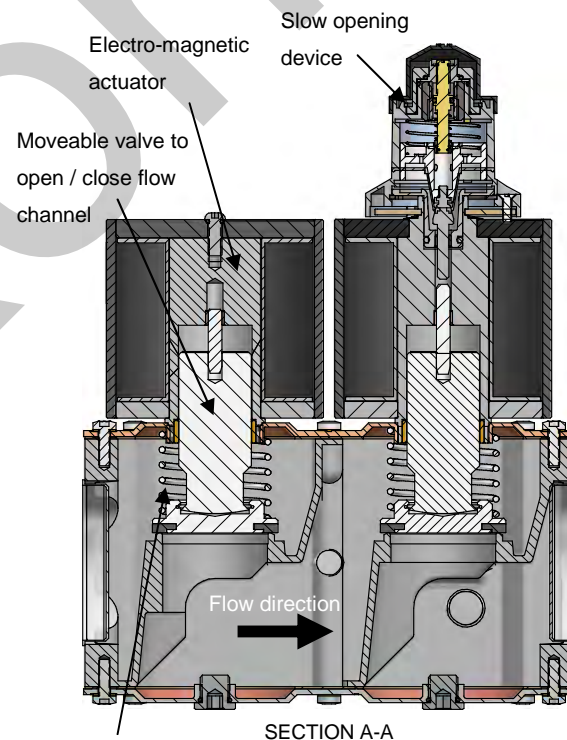

Automatic closing mechanism
when power is switched off

Figure 14 Schematic drawing of VQ400M.

ORDERING INFORMATION

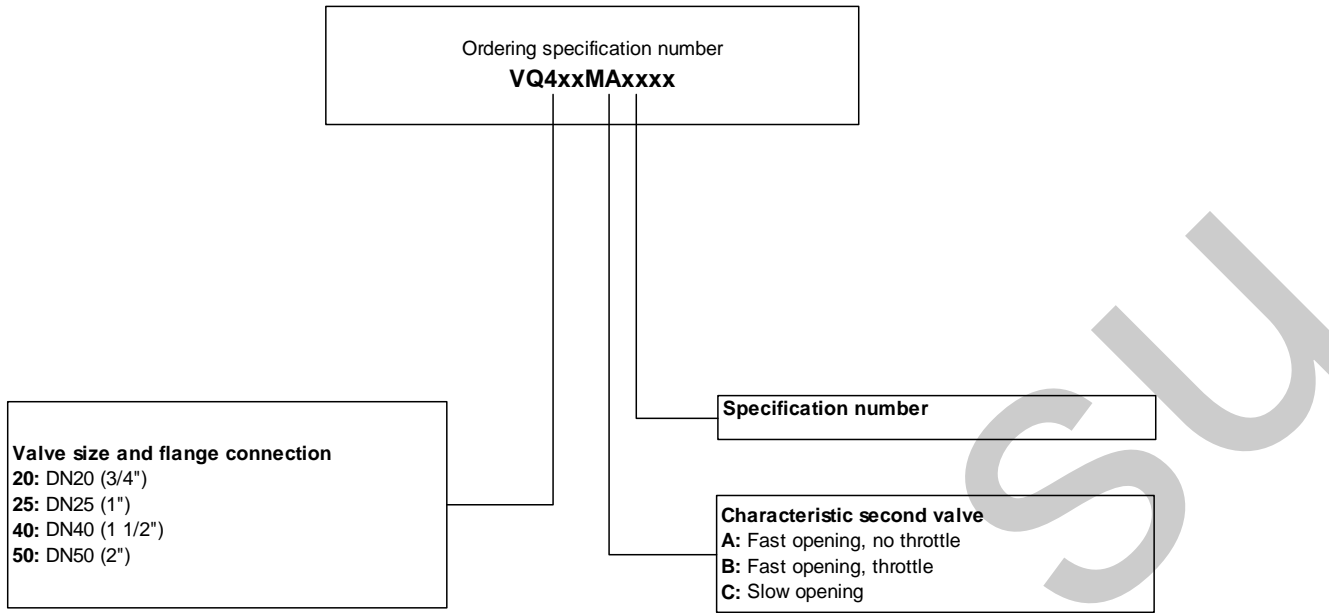

Figure 15 Ordering information VQ400M Series combination valves.

NOTE

Accessories as flanges need to be ordered separately.

REPLACEMENT OF PARTS

Warning

- Take care that only qualified persons carry out the installation of parts, accessories, and add on components.
- Follow the installation instructions included in the package.
- Check that the selected part, accessory or add-on component is the correct one for the application in question.
- Replace old gaskets with the new ones supplied in the package and check for leakage when the supply is switched on again.
- After installation and/or replacement has been completed, a gas leak test must be carried out.
- Also check the gas valve for satisfactory operation after fitting accessories.

Table 6 Rectifier boards for VQ400M series.

Gas valve	Rectifier board	
	115V/120V	230V
VQ420MA	CS020020	CS020070
VQ425MA	CS020020	CS020070
VQ440MA	CS020020	CS020071
VQ450MA	CS020020	CS020071

RECOMMENDED ACCESSORIES

There are two different series of flange kits available. The first series of flange kits consist of: 1 flange with sealing plug, 1 O-rings and 4 screws.

Table 7 Flange kits without strainer.

Gas valve	Recommended flange kit
VQ420M	KTCOMB15
VQ420M	KTCOMB20
VQ425M	KTCOMB25
VQ440M	KTCOMB32
VQ440M	KTCOMB40
VQ450M	KTCOMB50

The second series of flange kits consist of: 1 flange with sealing plug or cast pressure tap, 1 strainer, 1 O-rings and 4 screws

Table 8 Flange kits with strainer.

Gas valve	Recommended flange kit
VQ420M	KTCOMS15
VQ420M	KTCOMS20
VQ425M	KTCOMS25
VQ440M	KTCOMS32
VQ440M	KTCOMS40
VQ450M	KTCOMS50

Table 9 Overview of recommended internal by-pass valves.

Gas valve Internal by pass valve

VQ400M VB420Xxxxx



See Honeywell documentation VB420Xxxxx KIT for further instructions on internal by-pass valves.

Table 10 Overview of recommended external pilot valves.

Gas valve External pilot valve

VQ400M VP420Xxxxx



See Honeywell documentation VP420Xxxxx KIT for further instructions on external pilot valves.

Table 11 Overview of recommended vent valves.

Gas valve Vent valve

VQ400M VV420Xxxxx



See Honeywell documentation VV420Xxxx KIT for further instructions on vent valves.

Table 12 Overview of recommended closed position indication switches (CPI).

Gas valve Closed position indicator

VQ420M MS062001

VQ425M MS062501

VQ440M MS064001

VQ450M MS065001

Table 13 Honeywell fine particle filter.

Gasvalve Honeywell Filter

VQ420M HFVR050 / HFVR150

VQ425M



This filter is used to filter fine (50 or 150 µm) particles of dirt out of gas flow.

APPROVALS

The gas valve series **VQ400M** have been designed to meet the European standards:

- EN 161 Automatic shut-off valves
- EN 126 Multifunctional controls

Declaration of Conformity

Honeywell Technologies Sàrl.
Rolle,
Switzerland,

declares under it's sole responsibility that the VQ Modular Valve product family, to which this statement relates, is:

- in conformity with the essential requirements of the **Gas Appliance Directive 90/396/EEC** based on EN 126:2004
- in conformity with the essential requirements of the **Low Voltage Directive 2006/95/EC** based on EN 60730-1:2000
- in conformity with the essential requirements of the **EMC Directive 2004/108/EC**

for immunity based on the standard: **EN55014-2: 1997**
(Immunity, Product Family Standard)

for emission based on the standard: **EN55014-1: 2006**
(Emission , Product family standard)

Emmen, February 2009.

On behalf of Honeywell Technologies Sarl,

B.Veld, Manager Standards & Approvals

Honeywell

Manufactured for and on behalf of the Environmental and Combustion Controls Division of Honeywell Sàrl, Z.A. La Pièce 16, 1180 Rolle, Switzerland by its Authorized Representative:

Automation and Control Solutions

Combustion Controls Europe

Honeywell BV

Phileas Foggstraat 7

7821 AJ Emmen

The Netherlands

Tel.: +31 (-)591 695911

Fax: +31 (-) 591 695200

<http://europe.hbc.honeywell.com>