

UNIVERSAL GAS VALVES
MF4000 SERIES
 BUTTERFLY VALVE SERVOMOTORS

INSTRUCTION SHEET

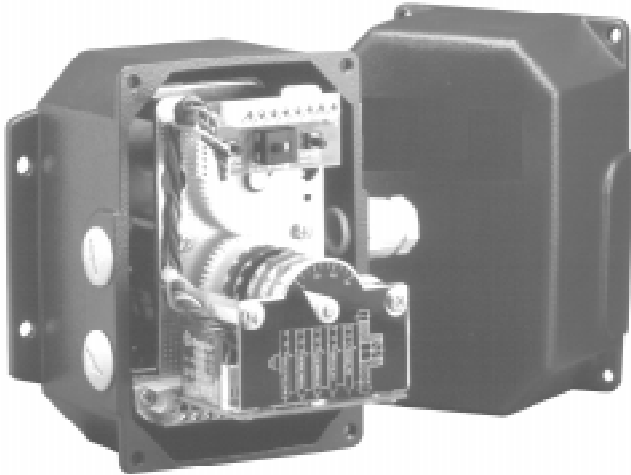

APPLICATION

The MF4000A, MF4000P and MF4000B are servo motors to control and govern airlock of gaseous and liquid fuels or to action the VF5000 series butterfly valves. These servo motors are suitable in burners with medium to high capacity.

SPECIFICATIONS

Models

MF4000A1 series to drive air dampers and VF5000 butterfly valves, with floating adjustment (see Figure 2.).
 MF4000P1 series to drive air dampers and VF5000 butterfly valves, with floating adjustment, with one or two feed-back potentiometers (see Figure 2.).
 MF4000B1 series to drive air dampers and VF5000 butterfly valves, with internal relay for ON/OFF adjustment (see Figure 3.).

Dimensions

See Fig. 1. Installation drawing MF4000 on page 2.

Supply voltages

Line voltage: 220 ... 240 Vac, 50/60 Hz
 110 Vac, 50/60 Hz

Maximum voltage

Current of microswitches: 250 Vac, 10 A (ac) and 2 A (dc)

Ambient temperature range

-15 ... 60°C

Rated torque

Maximum torque at 15s rotation time over 90 degrees: 5 Nm
 Maximum torque at 30s rotation time over 90 degrees: 10 Nm
 Maximum torque at 60s rotation time over 90 degrees: 15 Nm

Stroke timing

15, 30, 60 seconds at 50 Hz.
 At 60 Hz the timing is reduced with approximately 20%

Maximum adjustable stroke

0 to 90 degrees.

Enclosure

IP65

Minimum camshaft step

2 degrees (including mechanical tolerances)

Electrical connection

Two PG11 wiring conduits are provided in the housing.
 NOTE: Do not provide strain relief according to EN60730

Finish

The servo motor is mounted in a metal housing, which can be opened loosening 4 screws.

Design life

Model	Number of cycles
All models MF4000 Series	250.000

INSTALLATION

IMPORTANT

1. Installer must be a trained experienced service man.
2. Disconnect power supply to prevent electrical shock and/or equipment damage.
3. When the MF4000 is used in stand alone applications, use a proper strain-relief.
4. The appliance manufacturer's instructions should be followed when provided.
5. Carry out a thorough checkout when installation is completed.

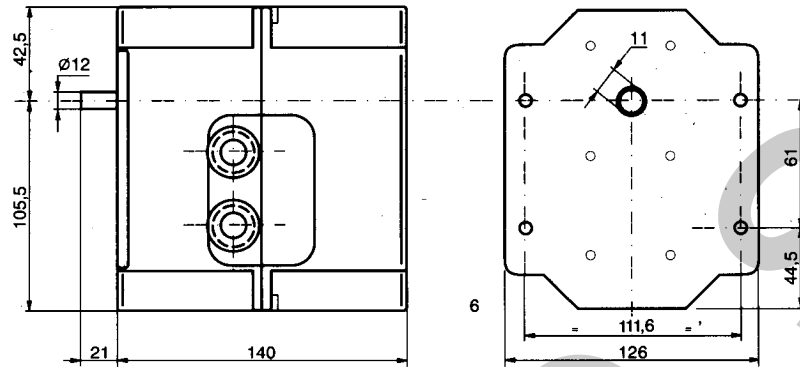

Fig. 1. Installation drawing MF4000 Series

Mounting and orientation

There are no mounting restrictions in the angle of the motor. The motor can be assembled by 4 screws. For mounting hole dimensions and positions, see installation drawing.

ADJUSTMENT AND CHECKOUT



WARNING

- Adjustment should be made by qualified personnel only.
- If the appliance manufacturer supplies checkout and/or service and maintenance instructions, carefully follow them.

Function of cams:

MF4000	
cam	
I (red)	Closed position for air damper motor
II (black)	Open position for air damper motor
III (blue)	Auxiliary switch
IV (green)	Auxiliary switch
V (yellow)	Auxiliary switch

Adjustment of cams

Disconnect power supply and remove cover. Use adjustment tool inside the cover to adjust the cams. Place the tool in one of the cam grooves to turn the cam in steps of approximately 2 degrees.

Factory set "zero position"

All motors are factory set with zero position corresponding with 45 degrees angle of flat surface on actuator shaft (see Figure 1.).

Auxiliary adjustment switches

To carry out the adjustment the auto-manual switch has to be set to manual. Three auxiliary switches are available Two push buttons are used for auxiliary switch regulation, one to open the damper, the other to close it.

Cam adjustment:

MF4000	
cam	
I (red)	Factory set at 0 degrees, to start the air damper in closed position
II/III/IV & V	Rotate the cam clockwise to reduce the position of the damper, anticlockwise to increase the position of the damper

ELECTRICAL CONNECTIONS

IMPORTANT

All wiring must comply with local and national codes of practice.

Ensure all valves are correctly earthed.

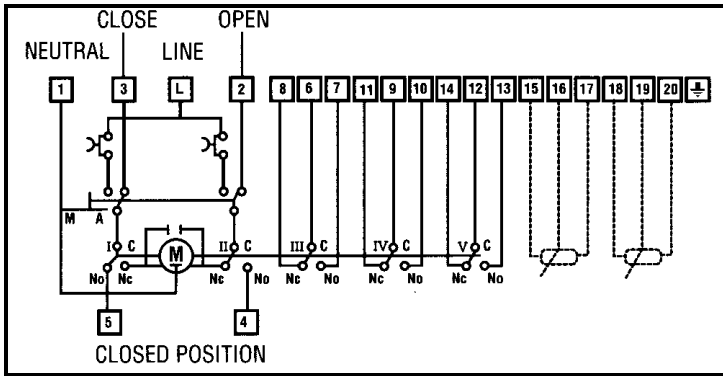

Fig. 2. Wiring diagram MF4000A and MF4000P

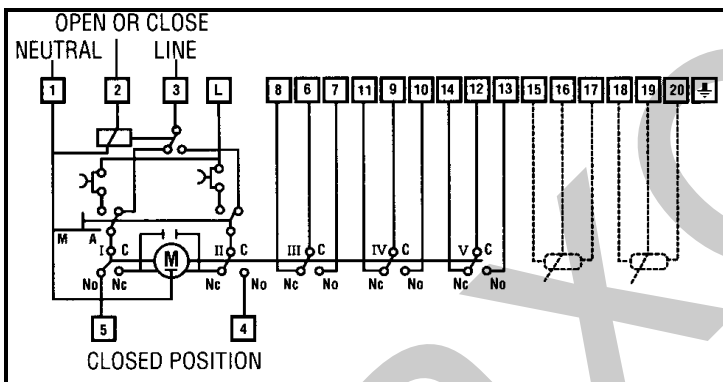

Fig. 3. Wiring diagram MF4000B

Honeywell

Helping You Control Your World

Honeywell U.G.V. S.r.l.
Via Ferrero, 16
10090 Cascine Vica - Rivoli (To)
Turin, Italy
Tel: +39 011 957 83 11
Fax: +39 011 957 83 22